



**OKП \* 4 – 7**  
**ТУ У 31.3-00214534-036-2004**

Fiber optic module-core cables, galvanized steel-wire armoured, with polyethylene outer sheath

**Mark formation:**

OKП-[a]-[b] [c]4([d]x[e]+[f])-7

[a] central strength element

- C – steel
- No marks – dielectric

[b] quantity of optical fibers in the cable, possible values

- 2, 4, 6, 8, 10, 12, 14, 16, 18, 20, 22, 24, 28, 30, 32, 52, 56, 60, 64

[c] type of optical fiber

- E – single-mode (ITU-T G.652B)
- A – single-mode with extended wavelength band (ITU-T G.652D, ITU-T G.657A1)
- C – single-mode with non-zero shifted dispersion (ITU-T G.655)
- M – multimode with core and sheath diameter ratio 50 : 125 mm (ITU-T G.651)
- B – multimode with core and sheath diameter ratio 62.5 : 125 mm (IEC 60793-2)

[d] 1 ... 4 – number of optical modules in cable

[e] quantity of optical fibers in the module:

- 1 ... 16

(f) quantity of insulated copper conductors in cable

Optical modules are completed with string fillers up to total number of core elements

Manufacturing of cables with two copper insulated remote power conductors instead of two string fillers is possible

Manufacturing of cables in climate version F is possible

Manufacturing of cables with steel strength element is possible

Manufacturing of cables with flame-retardant polymer compound outer sheath is possible

Manufacturing of cables with allowable tensile force 10 kN is possible

It is possible to manufacture cables with gel-filled core or dry core (with water-blocking yarns and tapes)

It is possible to manufacture cables with a number of core elements up to and including 18

Order placing: sample of indication (corresponds to configuration pattern)

OKП-10A4(2x4+1x2)-7 • ТУ У 31.3-00214534-036-2004

Cables are used for:

- *mechanical laying in soils of all categories (except for soils subjected to cryosolic and other distortions) and groups in open trench; in cable ducts, pipes, blocks; under impact of significant tensile forces on cable*

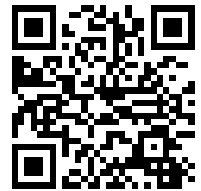

**ОКП \* 4 – 7**  
**ТУ У 31.3-00214534-036-2004**

Fiber optic module-core cables, galvanized steel-wire armoured, with polyethylene outer sheath

**TECHNICAL SPECIFICATIONS**

Number of cable core elements	units	4
Number of optical fibers in cable	units	2 ... 64
Electrical resistance of sheath insulation, not less than	MOhm · km	2000
Permissible tensile force	kN	7
Permissible crushing force, no less than	N/10 sm	5000
Operating temperature range	°C	-40 ... +60
Operating temperature range (in climate version F)	°C	-60 ... +60
Cable weight (approximate, depending on construction)	kg/km	355 ... 435
Rated outer diameter of the cable (for reference only, depending on construction) **	mm	14 ... 16
Minimum bending radius during laying	mm	320
Rated factory cable length and gross weight of the delivery on the drums	m, t	# 12a: 2360 · 1.0 # 14: 3210 · 1.3

Notes:

When ordering it is necessary to agree the factory length of the product with the manufacturer

\*\* The external diameter may differ from the rated up to  $\pm 10\%$

**CONSTRUCTION**

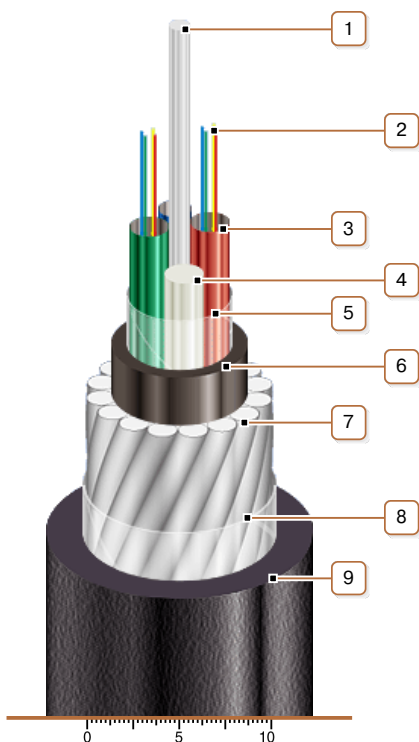

**1. Central dielectric strength element**

Note: Manufacturing of cables with steel strength element is possible

**2. Optic fibers**

**3. Tube of fiber optic module**

**4. String filler**

Note: Optical modules are completed with string fillers up to total number of core elements

**5. PET film winding**

**6. Polyethylene inner sheath**

**7. Round galvanized steel-wire armour**

**8. PET film winding**

**9. Polyethylene outer sheath**

Note: Manufacturing of cables with flame-retardant polymer compound outer sheath is possible

Notes:

- Optical module twisting is not illustrated.
- Manufacturing of cables with two copper insulated remote power conductors instead of two string fillers is possible
- It is possible to manufacture cables with gel-filled core or dry core (with water-blocking yarns and tapes)
- It is possible to manufacture cables with a number of core elements up to and including 18