

ЦСБ 3x150-6 TY Y 27.3-00214534-091:2017

Power cables with copper conductors, with non-draining impregnated paper insulation, lead-sheathed, steel-tape armoured

Cables are used for laying:

- without level difference limitation
- in soil (trenches) with medium corrosiveness without vagabond currents
- in soil (trenches) with low corrosiveness, as well as with vagabond currents
- in mines, non-hazardous as for gas and dust
- with a risk of mechanical damage and no tensile forces in operation

TECHNICAL SPECIFICATIONS

| | | |
|--|-----------------|-------------------------------------|
| Rated voltage | kV | 6 |
| Number and rated area of conductors | mm ² | 3 x 150 |
| Insulation thickness between conductors | mm | 4 |
| Insulation thickness of conductor-sheath | mm | 2.95 |
| Sheath thickness | mm | 1.52 |
| Permissible continuous current rating * | | |
| • by aerial laying | A | 392 |
| • by burial | A | 358 |
| Operating temperature range | °C | -50 ... +50 |
| Minimum bending radius by laying | mm | 780 |
| Metal sheath outer diameter (for reference only) | mm | 39 |
| Rated outer diameter of the cable (for reference) ** | mm | 52 |
| Cable weight (approximate) | kg/km | 8310 |
| Rated factory cable length and gross weight of the delivery on the drums | m, t | # 16a: 370 • 3.3 # 18: 430 • 4.0 |

Notes:

When ordering it is necessary to agree the factory length of the product with the manufacturer

* Long permissible current loads are calculated for the following conditions: air temperature plus 25 °C, soil temperature plus 15 °C, thermal resistivity of soil 1.2 °K·m/W, laying depth in the soil 0.7 m

** The external diameter may differ from the rated up to ± 10 %

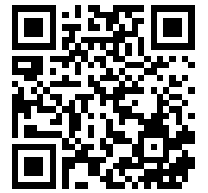

ЦСБ 3x150-6
ТУ У 27.3-00214534-091:2017

Power cables with copper conductors, with non-draining impregnated paper insulation, lead-sheathed, steel-tape armoured

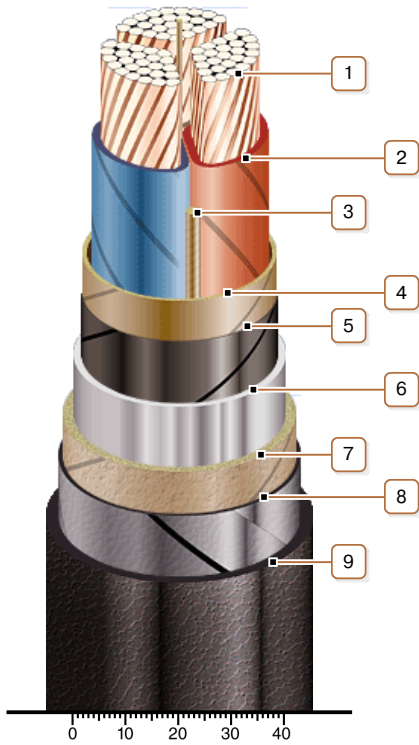

CONSTRUCTION

1. Copper multiwire compact conductor
2. Impregnated paper insulation
3. Cable paper bundle
4. Belt insulation
5. Conducting paper screen
6. Lead sheath
7. Bedding
8. Double steel-tape armour
9. Outer covering

Note: Conductor twisting is not illustrated