

## ЦАСПл 3x185-6 ТУ У 27.3-00214534-091:2017

Power cables with aluminium conductors, with non-draining impregnated paper insulation, lead-sheathed, steel-wire armoured

Cables are used for laying:

- without level difference limitation
- in soil (trenches) with medium corrosiveness, as well as with vagabond currents
- with a risk of mechanical damage and tensile forces in operation

### TECHNICAL SPECIFICATIONS

|  |                 |   |
|--|-----------------|---|
| Rated voltage  | kV              | 6   |
| Number and rated area of conductors                                      | mm <sup>2</sup> | 3 x 185   |
| Insulation thickness between conductors                                  | mm              | 4   |
| Insulation thickness of conductor-sheath                                 | mm              | 2.95  |
| Sheath thickness   | mm              | 1.62  |
| Permissible continuous current rating *                                  |                 |   |
| • by aerial laying   | A               | 333   |
| • by burial  | A               | 307   |
| Operating temperature range  | °C              | -50 ... +50   |
| Minimum bending radius by laying   | mm              | 915   |
| Metal sheath outer diameter (for reference only)                         | mm              | 45  |
| Rated outer diameter of the cable (for reference) **                     | mm              | 61  |
| Cable weight (approximate)   | kg/km           | 7960  |
| Rated factory cable length and gross weight of the delivery on the drums | m, t            | # 18: 270 • 2.6<br># 20: 440 • 4.1<br># 22: 500 • 4.8 |

Notes:

When ordering it is necessary to agree the factory length of the product with the manufacturer

\* Long permissible current loads are calculated for the following conditions: air temperature plus 25 °C, soil temperature plus 15 °C, thermal resistivity of soil 1.2 °K·m/W, laying depth in the soil 0.7 m

\*\* The external diameter may differ from the rated up to ± 10 %

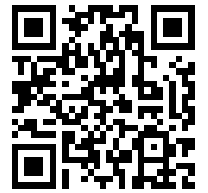

**ЦАСПл 3x185-6**  
**ТУ У 27.3-00214534-091:2017**

Power cables with aluminium conductors, with non-draining impregnated paper insulation, lead-sheathed, steel-wire armoured

**CONSTRUCTION**

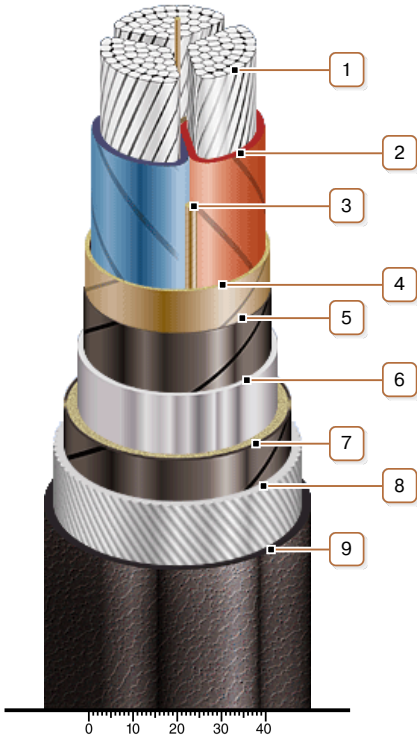

1. Aluminium multiwire compacted conductor
2. Impregnated paper insulation
3. Cable paper bundle
4. Belt insulation
5. Conducting paper screen
6. Lead sheath
7. Single-layer plastic-tape bedding
8. Round galvanized steel-wire armour
9. Outer covering

Note: Conductor twisting is not illustrated