



## **АПВЭКПγ-15 3x300 ТУ У 31.3-00214534-017-2003**

Three-core power cables with aluminium conductors, with XLPE, steel-wire armoured, with strengthened polyethylene outer sheath

---

Technical cable requirements correspond to IEC 60502-2

Cables are used for laying:

- *in places, where mechanical impacts on cable are possible, including tensile forces*
- *in soil (trenches)*
- *on difficult route sections, according to the unique specification*
- *in the air, including cable structures, if provided the additional fire protection*

---

It is possible to manufacture cables with extruded semiconductor layer along outer sheath.

Order entry example:

АПВЭКПγ-П-15 3x300/25 ТУ У 31.3-00214534-017-2003

An extruded semiconductor layer along outer sheath ensures the correct testing of cable line with sections of underground laying in polymer pipes.

---

It is possible to manufacture cables with an integrated fiber-optic module.

Order entry example:

АПВЭКПγ-15 3x300/25 (OM) ТУ У 31.3-00214534-017-2003

In conjunction with the DTS system, the integrated fiber-optic module can act as a distributed cable line temperature sensor.

---

It is possible to manufacture cable with sealed conductors.

Order entry example:

АПВЭКПγ-15 3x300/25 (r) ТУ У 31.3-00214534-017-2003

---



## АПВЭКПы-15 3x300 ТУ У 31.3-00214534-017-2003

Three-core power cables with aluminium conductors, with XLPE, steel-wire armoured, with strengthened polyethylene outer sheath

### TECHNICAL SPECIFICATIONS

|  |                 |  |
|--|-----------------|--|
| Rated voltage  | kV              | 15   |
| Maximum voltage  | kV              | 17.5   |
| Number and rated area of conductors  | mm <sup>2</sup> | 3 x 300  |
| Insulation thickness   | mm              | 4.5  |
| Minimum screen cross-section   | mm <sup>2</sup> | 25   |
| Permissible short circuit current across the screen of minimum cross-section | kA              | 5.1  |
| Maximum permissible short-circuit current in core                            | kA              | 28.2   |
| Permissible continuous current rating *                                      |                 |  |
| • by aerial laying   | A               | 472  |
| • by burial  | A               | 380  |
| Partial discharge factor for rated voltage, not more than                    | pC              | 6  |
| Maximum permissible conductor temperature                                    |                 |  |
| • Continuous   | °C              | +90  |
| • in emergency operation   | °C              | +130   |
| • at short circuit   | °C              | +250   |
| Operating temperature range  | °C              | -60 ... +50  |
| Minimum bending radius by laying   | mm              | 1488   |
| Rated outer diameter of the cable (for reference) **                         | mm              | 93   |
| Cable weight (approximate)   | kg/km           | 12840  |
| Rated factory cable length and gross weight of the delivery on the drums     | m, t            | # 25УД-90: 283 • 5.2<br># 26УД-100: 433 • 7.4<br># 30УД-130: ***556 • 10.0 |

#### Notes:

When ordering it is necessary to agree the factory length of the product with the manufacturer

\* Long permissible current loads are calculated for the following conditions: conductor temperature 90 °C, air temperature 30 °C, soil temperature 20 °C, load factor 1.0, thermal resistivity of soil 1.5 °K·m/W, laying depth in the ground 0.8 m, shields are grounded at both ends of the line

\*\* The external diameter may differ from the rated up to ± 10 %

\*\*\* Option delivery on not full drum



## АПвЭКПу-15 3x300 ТУ У 31.3-00214534-017-2003

Three-core power cables with aluminium conductors, with XLPE, steel-wire armoured, with strengthened polyethylene outer sheath

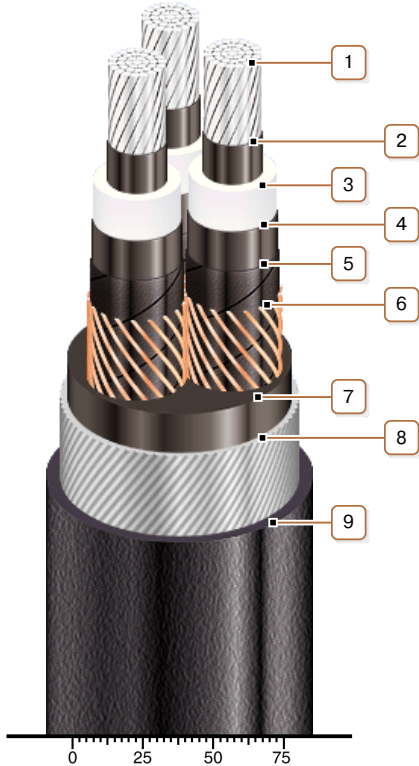

### CONSTRUCTION

**1. Aluminium multiwire compacted conductor**

*Note: It is possible to manufacture cable with sealed conductors.*

**2. Inner extruded semiconducting layer**

**3. XLPE insulation**

**4. Outer extruded semiconducting layer**

**5. Lapping layer of semiconductive swellable tape**

**6. Copper screen**

*Note: It is possible to manufacture a cable with a fiber optic module built into the screen, including as a DTS system sensor*

**7. Extruded filling of PVC compound**

**8. Round galvanized steel-wire armour**

**9. Strengthened polyethylene outer sheath**

*Note: It is possible to manufacture cable with extruded semiconductor layer along outer sheath*

*Note: Conductor twisting is not illustrated*