



## **АПвЭБВнгд-10 3х240 ТУ У 31.3-00214534-017-2003**

Three-core power cables with aluminium conductors, flame-retardant, with XLPE, steel-tape armoured, with PVC compound outer sheath, with low smoke and gas emission

For the cable of this mark correspond the foreign-made analogues:

АПвБВнг(В)-LS (RU) · АПвБВнг(А)-LS (RU)

Technical cable requirements correspond to IEC 60502-2

Cables are used for laying:

- *in places, where mechanical impacts on cable are possible, except tensile forces*
- *in premises, tunnels, ducts, mines, dry soil and outdoor under shelter*
- *in bunches*
- *at sites, where low smoke and gas emission are required (NPP, subway, large industrial facilities, high-rise buildings, etc.)*

It is possible to manufacture cables with an integrated fiber-optic module.

Order entry example:

АПвЭБВнгд-10 3х240/25 (ОМ) ТУ У 31.3-00214534-017-2003

In conjunction with the DTS system, the integrated fiber-optic module can act as a distributed cable line temperature sensor.

It is possible to manufacture cable with sealed conductors.

Order entry example:

АПвЭБВнгд-10 3х240/25 (Г) ТУ У 31.3-00214534-017-2003

Fire safety code in accordance with ДСТУ 4809:2007: ПБ122121000

Products of this mark meet the requirements:

- *single wire cable flame retardance*
- *bunched cable flame retardance category A*
- *toxicity class Tk2 of the combustion products of nonmetallic elements (toxicity index from 40 up to 120 g/m<sup>3</sup>)*
- *class ДТк1 on smoke-forming ability by smouldering of non-metallic elements (coefficient of smoke formation from 50 to 500 m<sup>2</sup>/kg)*
- *class ДПк2 on smoke-forming ability by combustion (minimum luminous flux more than 60 %)*
- *corrosive class Кк1 of combustion products of non-metallic elements (the number of halogen hydrides less than 150 mg/g, pH less than 4.3, specific conductivity more than 10 μS/mm)*



## АПвЭБВнгд-10 3x240 ТУ У 31.3-00214534-017-2003

Three-core power cables with aluminium conductors, flame-retardant, with XLPE, steel-tape armoured, with PVC compound outer sheath, with low smoke and gas emission

### TECHNICAL SPECIFICATIONS

|  |                 |                      |
|--|-----------------|----------------------|
| Rated voltage  | kV              | 10                   |
| Maximum voltage  | kV              | 12                   |
| Number and rated area of conductors  | mm <sup>2</sup> | 3 x 240              |
| Insulation thickness   | mm              | 3.4                  |
| Minimum screen cross-section   | mm <sup>2</sup> | 25                   |
| Permissible short circuit current across the screen of minimum cross-section | kA              | 5.1                  |
| Maximum permissible short-circuit current in core                            | kA              | 22.7                 |
| Permissible continuous current rating *                                      |                 |                      |
| • by aerial laying   | A               | 415                  |
| • by burial  | A               | 338                  |
| Partial discharge factor for rated voltage, not more than                    | pC              | 6                    |
| Maximum permissible conductor temperature                                    |                 |                      |
| • Continuous   | °C              | +90                  |
| • in emergency operation   | °C              | +130                 |
| • at short circuit   | °C              | +250                 |
| Operating temperature range (in climate version NF)                          | °C              | -50 ... +50          |
| Operating temperature range (in climate version T)                           | °C              | -25 ... +65          |
| Minimum bending radius by laying   | mm              | 1232                 |
| Rated outer diameter of the cable (for reference) **                         | mm              | 77                   |
| Cable weight (approximate)   | kg/km           | 8350                 |
| Rated factory cable length and gross weight of the delivery on the drums *** | m, t            | # 25УД-90: 443 • 5.3 |

#### Notes:

When ordering it is necessary to agree the factory length of the product with the manufacturer

\* Long permissible current loads are calculated for the following conditions: conductor temperature 90 °C, air temperature 30 °C, soil temperature 20 °C, load factor 1.0, thermal resistivity of soil 1.5 °K·m/W, laying depth in the ground 0.8 m, shields are grounded at both ends of the line

\*\* The external diameter may differ from the rated up to ± 10 %

\*\*\* Отклонение фактической массы брутто от указанного значения может составлять ± 7 %



## АПвЭБВнгд-10 3х240 ТУ У 31.3-00214534-017-2003

Three-core power cables with aluminium conductors, flame-retardant, with XLPE, steel-tape armoured, with PVC compound outer sheath, with low smoke and gas emission

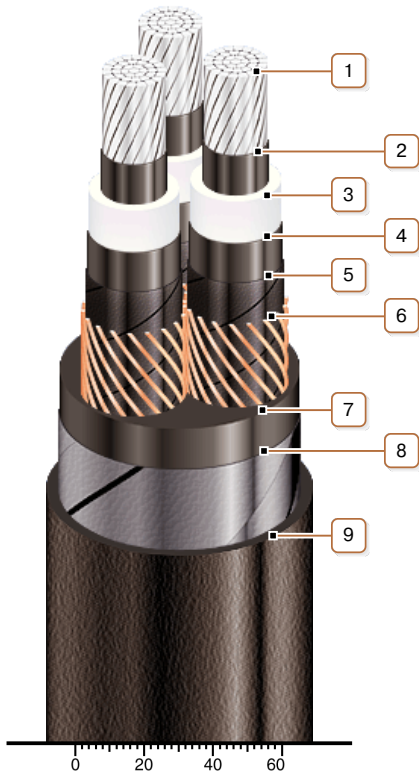

### CONSTRUCTION

#### 1. Aluminium multiwire compacted conductor

Notes:

- It is possible to manufacture cable with a single-wire conductor
- It is possible to manufacture cable with sealed conductors.

#### 2. Inner extruded semiconducting layer

#### 3. XLPE insulation

#### 4. Outer extruded semiconducting layer

#### 5. Lapping layer of semiconductive swellable tape

#### 6. Copper screen

Note: It is possible to manufacture a cable with a fiber optic module built into the screen, including as a DTS system sensor

#### 7. Extruded filling of low fire-risk PVC compound

#### 8. Double galvanized steel-tape armour

#### 9. Low fire-risk PVC compound outer sheath

Note: Conductor twisting is not illustrated