



## **АПвЭоПы(κ)-10 3x300 ТУ У 31.3-00214534-017-2003**

Three-core power cables with aluminium conductors, with XLPE, collective screen and strengthened outer polyethylene sheath

---

Technical cable requirements correspond to IEC 60502-2

Cables are used for laying:

- *in soil (trenches)*
- *on difficult route sections, according to the unique specification*
- *in the air, including cable structures, if provided the additional fire protection*

---

It is possible to manufacture cables with extruded semiconductor layer along outer sheath.

Order entry example:

АПвЭоПы(κ)-П-10 3x300/70 ТУ У 31.3-00214534-017-2003

An extruded semiconductor layer along outer sheath ensures the correct testing of cable line with sections of underground laying in polymer pipes.

---

It is possible to manufacture cables with an integrated fiber-optic module.

Order entry example:

АПвЭоПы(κ)-10 3x300/70 (OM) ТУ У 31.3-00214534-017-2003

In conjunction with the DTS system, the integrated fiber-optic module can act as a distributed cable line temperature sensor.

---

It is possible to manufacture cable with sealed conductors.

Order entry example:

АПвЭоПы(κ)-10 3x300/70 (r) ТУ У 31.3-00214534-017-2003

---



## АПвЭопу(к)-10 3x300 ТУ У 31.3-00214534-017-2003

Three-core power cables with aluminium conductors, with XLPE, collective screen and strengthened outer polyethylene sheath

### TECHNICAL SPECIFICATIONS

|  |                 |   |
|--|-----------------|---|
| Rated voltage  | kV              | 10  |
| Maximum voltage  | kV              | 12  |
| Number and rated area of conductors  | mm <sup>2</sup> | 3 x 300                                       |
| Insulation thickness   | mm              | 3.4   |
| Minimum screen cross-section   | mm <sup>2</sup> | 70  |
| Permissible short circuit current across the screen of minimum cross-section | kA              | 14.2  |
| Maximum permissible short-circuit current in core                            | kA              | 28.2  |
| Permissible continuous current rating *                                      |                 |   |
| • by aerial laying   | A               | 475   |
| • by burial  | A               | 384   |
| Partial discharge factor for rated voltage, not more than                    | pC              | 6   |
| Maximum permissible conductor temperature                                    |                 |   |
| • Continuous   | °C              | +90   |
| • in emergency operation   | °C              | +130  |
| • at short circuit   | °C              | +250  |
| Operating temperature range  | °C              | -60 ... +50                                   |
| Minimum bending radius by laying   | mm              | 1248  |
| Rated outer diameter of the cable (for reference) **                         | mm              | 78  |
| Cable weight (approximate)   | kg/km           | 7120  |
| Rated factory cable length and gross weight of the delivery on the drums     | m, t            | # 25УД-90: 443 • 4.7<br># 26УД-100: 631 • 6.3 |

**Notes:**

When ordering it is necessary to agree the factory length of the product with the manufacturer

\* Long permissible current loads are calculated for the following conditions: conductor temperature 90 °C, air temperature 30 °C, soil temperature 20 °C, load factor 1.0, thermal resistivity of soil 1.5 °K·m/W, laying depth in the ground 0.8 m, shields are grounded at both ends of the line

\*\* The external diameter may differ from the rated up to ± 10 %



## АПвЭоПу(к)-10 3x300 ТУ У 31.3-00214534-017-2003

Three-core power cables with aluminium conductors, with XLPE, collective screen and strengthened outer polyethylene sheath

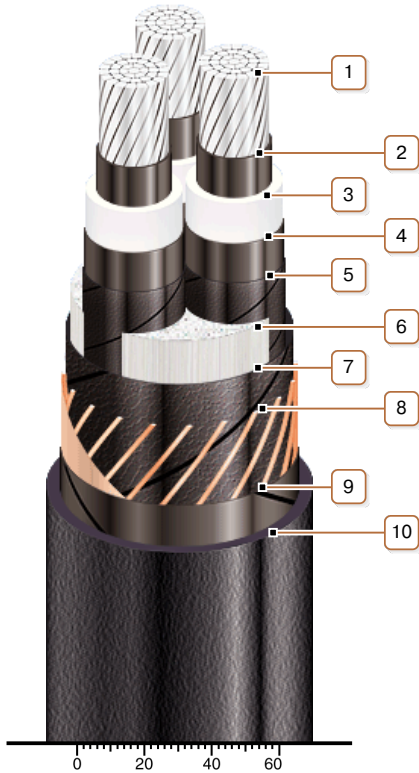

### CONSTRUCTION

**1. Aluminium multiwire compacted conductor**

*Note: It is possible to manufacture cable with sealed conductors.*

**2. Inner extruded semiconducting layer**

**3. XLPE insulation**

**4. Outer extruded semiconducting layer**

**5. Lapping layer of semiconductive swellable tape**

**6. Interstitial filler with polypropylene bundles**

**7. Lapping layer of semiconductive swellable tape**

**8. Copper screen**

**9. Lapping layer of synthetic paper**

**10. Strengthened polyethylene outer sheath**

*Note: It is possible to manufacture cable with extruded semiconductor layer along outer sheath*

*Note: Conductor twisting is not illustrated*