

ОБГПН * 5 – 2.7 ТУ У 31.3-00214534-036-2004

Fiber optic module-core cables, corrugated steel-tape armoured, with polymer compound flame-retardant outer sheath

Mark formation:

ОБГПН-[a]-[b] [c]5([d]x[e]+[f])-2.7

[a] central strength element

- C – steel
- No marks – dielectric

[b] quantity of optical fibers in the cable, possible values

- 8, 14, 16, 18, 20, 24, 26, 28, 30, 32, 36, 40, 48, 60, 65, 70, 75, 80

[c] type of optical fiber

- E – single-mode (ITU-T G.652B)
- A – single-mode with extended wavelength band (ITU-T G.652D, ITU-T G.657A1)
- C – single-mode with non-zero shifted dispersion (ITU-T G.655)
- M – multimode with core and sheath diameter ratio 50 : 125 mm (ITU-T G.651)
- B – multimode with core and sheath diameter ratio 62.5 : 125 mm (IEC 60793-2)

[d] 2 ... 5 – number of optical modules in cable

[e] quantity of optical fibers in the module:

- 1 ... 16

[f] quantity of insulated copper conductors in cable

Optical modules are completed with string fillers up to total number of core elements

Manufacturing of cables with two copper insulated remote power conductors instead of two string fillers is possible

Manufacturing of cables in climate version F is possible

Manufacturing of cables with steel strength element is possible

Manufacturing of cables with dielectric armour (of glass fiber rod) is possible

It is possible to manufacture cables with gel-filled core or dry core (with water-blocking yarns and tapes)

It is possible to manufacture cables with a number of core elements up to and including 18

Order placing: sample of indication (corresponds to configuration pattern)

ОБГПН-18A5(3x6+2)-2.7 • ТУ У 31.3-00214534-036-2004

Cables are used for:

- installation in pipes (including air installation method), blocks, collectors at risk of damage by rodents, as well as in soil by mechanical method
- in areas with exclusive fire safety requirements

Fire safety code in accordance with ДСТУ 4809:2007: ПБ130122000

Products of this mark meet the requirements:

- single wire cable flame retardance
- bunched cable flame retardance category B
- class ДТк1 on smoke-forming ability by smouldering of non-metallic elements (coefficient of smoke formation from 50 to 500 m²/kg)
- class ДПк2 on smoke-forming ability by combustion (minimum luminous flux more than 60 %)
- corrosive class Кк2 of combustion products of non-metallic elements (the number of halogen hydrides less than 150 mg/g, pH more than 4.3, specific conductivity less than 10 μS/mm)

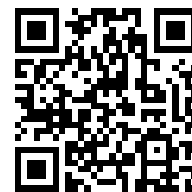

ОБГПн * 5 – 2.7
ТУ У 31.3-00214534-036-2004

Fiber optic module-core cables, corrugated steel-tape armoured, with polymer compound flame-retardant outer sheath

TECHNICAL SPECIFICATIONS

Number of cable core elements	units	5
Number of optical fibers in cable	units	8 ... 80
Electrical resistance of sheath insulation, not less than	MOhm · km	2000
Permissible tensile force	kN	2.7
Permissible crushing force, no less than	N/10 sm	3000
Operating temperature range	°C	-40 ... +60
Operating temperature range (in climate version F)	°C	-60 ... +60
Cable weight (approximate, depending on construction)	kg/km	260 ... 290
Rated outer diameter of the cable (for reference only, depending on construction) **	mm	15 ... 16
Minimum bending radius during laying	mm	320
Rated factory cable length and gross weight of the delivery on the drums ***	m, t	# 12a: 2060 · 0.7 # 14: 2790 · 0.9

Notes:

When ordering it is necessary to agree the factory length of the product with the manufacturer

** The external diameter may differ from the rated up to ± 10 %

CONSTRUCTION

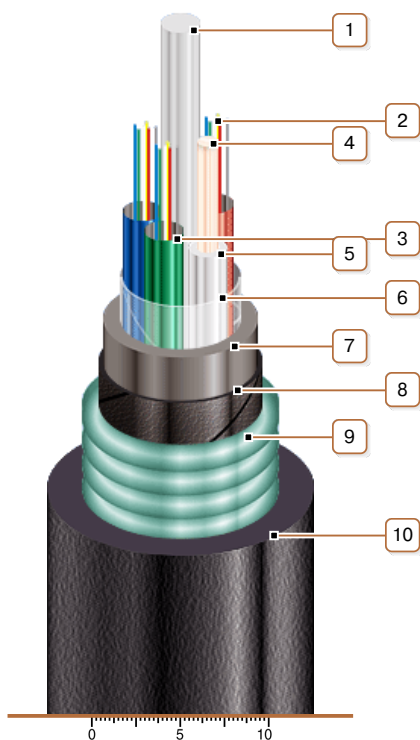

1. Central dielectric strength element

Note: Manufacturing of cables with steel strength element is possible

2. Optic fibers

3. Tube of fiber optic module

4. Remote power copper conductor

5. Polyethylene insulation

6. PET film winding

7. Polymer compound inner sheath

8. Lapping layer of water-blocking tape or thread

9. Armour of corrugated steel tape, polyethylene-laminated

Note: Manufacturing of cables with dielectric armour (of glass fiber rod) is possible

10. Flame-retardant polymer compound outer sheath

Notes:

- Optical module twisting is not illustrated.
- Manufacturing of cables with two copper insulated remote power conductors instead of two string fillers is possible
- It is possible to manufacture cables with gel-filled core or dry core (with water-blocking yarns and tapes)
- It is possible to manufacture cables with a number of core elements up to and including 18